



# CARBIDE TIPPED SPECIALS QUOTE FORM

REQUIRED INFORMATION FOR QUOTING AND ORDERING  
 FAX TO 573-221-1140 or E-MAIL TO sales@hannibalcarbide.com

TECHNICAL

## CARBIDE TIPPED - ARBOR TYPE TOOLS

- D= \_\_\_\_\_ Cutter Diameter
- W= \_\_\_\_\_ Cutter Width
- A= \_\_\_\_\_ Arbor Hole Diam.
- N= \_\_\_\_\_ # of Teeth
- H= \_\_\_\_\_ Hub Diameter
- K= \_\_\_\_\_ Keyway Size
- R1= \_\_\_\_\_ Radius/Chamfer
- R2= \_\_\_\_\_ Radius/Chamfer

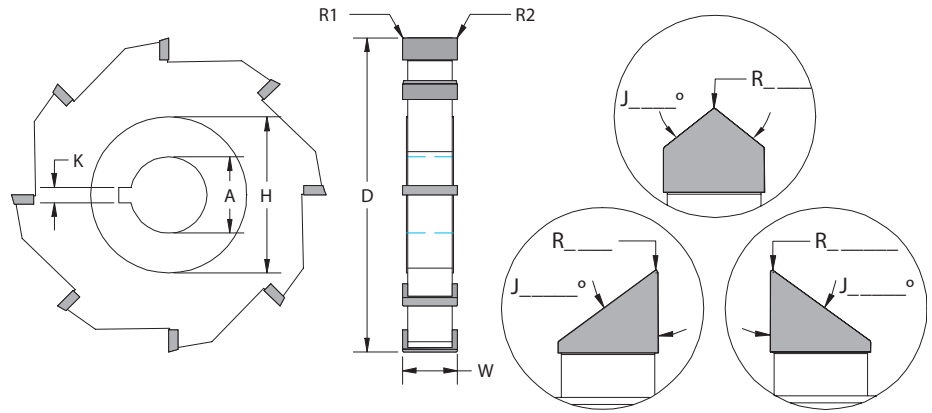

- Straight Tooth
- Straight Stagger
- Herringbone Stagger

- MILLING CUTTER
- SLITTING SAW

- ANGLE CUTTER  
(Fill in "J" & "R")

## QUOTE REQUEST FORM:

INDIVIDUAL: \_\_\_\_\_

COMPANY: \_\_\_\_\_

CITY/STATE: \_\_\_\_\_

FAX #: \_\_\_\_\_ PHONE #: \_\_\_\_\_

QUANTITY BREAKS: \_\_\_\_\_ pcs \_\_\_\_\_ pcs \_\_\_\_\_ pcs \_\_\_\_\_ pcs

Chip class of MATERIAL BEING MACHINED (from page 6-8)

- 20
- 40
- 60
- 80
- 100
- 120
- 140
- Other Material \_\_\_\_\_

*Special order tool quotes usually same day; always next. Over 96% of Special tool orders shipped on promise date.*

